

Software Errors

If a drive fault is reported the fault may be a software problem. Before investigating the drive please carry out the following checks to ensure it is not a software problem.

Detection and Correction of "Soft Errors"

Soft errors are usually caused by the following reasons.

- 1) Random external noise of several usec or less.
- 2) Minute off-tracking and shifting of write timing that are not detected during the write operation which may cause the soft error during the read.

To remedy such soft errors, take the following procedures at the controller side.

- 1) Repetitive reading on the track by 10 times or more until the data is restored.
- 2) When the data is not restored by step 1, access the head to the adjacent track in the same direction as move previously, and thereafter return the head to the original track.
- 3) Repeat the step 1.
- 4) If the data is not restored by the above steps, the error cannot be remedied.

Write Error

When an error is caused during the write operation, the error is usually detected during the next rotation through the read operation called "Write Check".

To correct the error, repeat the write operation again and carry out the Write Check.

If the result is still incorrect even after the write operation is repeated more than 10 times, either the disc or the drive are working incorrectly. To find out the trouble source, carry out the read operations with another track. Should the error still be found, change the disc and repeat the above procedures. Should error still be found, the disc drive should be considered defective. If the error is removed, the original disc must be defective. Discard it.

Seek Error

- 1) Step motor or step motor drive circuit is defective.
- 2) The torque of the carriage is not correct.

Restoration procedures from the seek error.

Make the re-calibration to the track 00. Then, carry out the re-seek to the original track.

Notes:

- 1) Always ensure the head is clean.
- 2) Index/Sector Factor (Ready Defect)

As the unit has Optional Read Output

It is normally not ready until 2 revolutions are made after the disc insertion.

Read Error

Most of the errors are "Soft Errors", in such a case the data are restored by following "Detection and Correction of Soft Errors" correction procedure.

Diagnostic Flow Chart For FD4

This chart must be used in conjunction with
the Alignment Procedures

This chart is for information only and
does not guarantee an exact diagnosis.
For warranty purposes any faulty drive
mechanism must be returned to Amstrad
for replacement. Service Agents should
not attempt any repairs on the mechanism
or to its P.C.B.

3-A

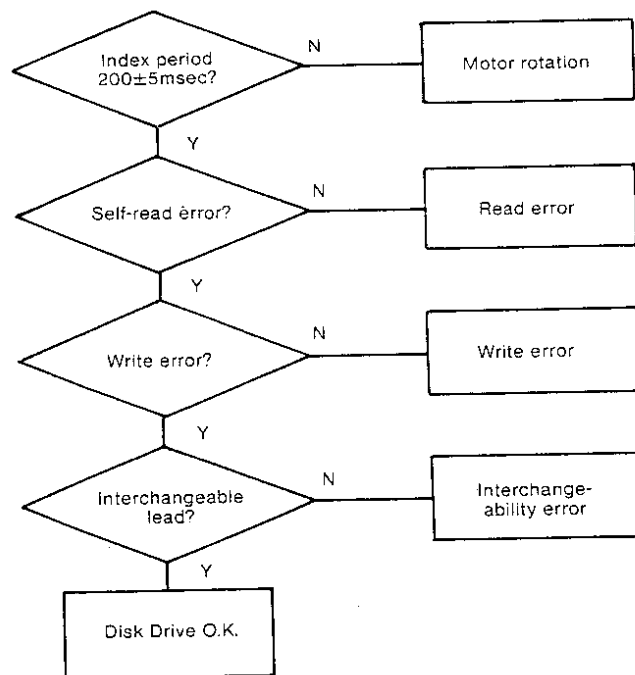

FLOW CHART (cont)

3--B

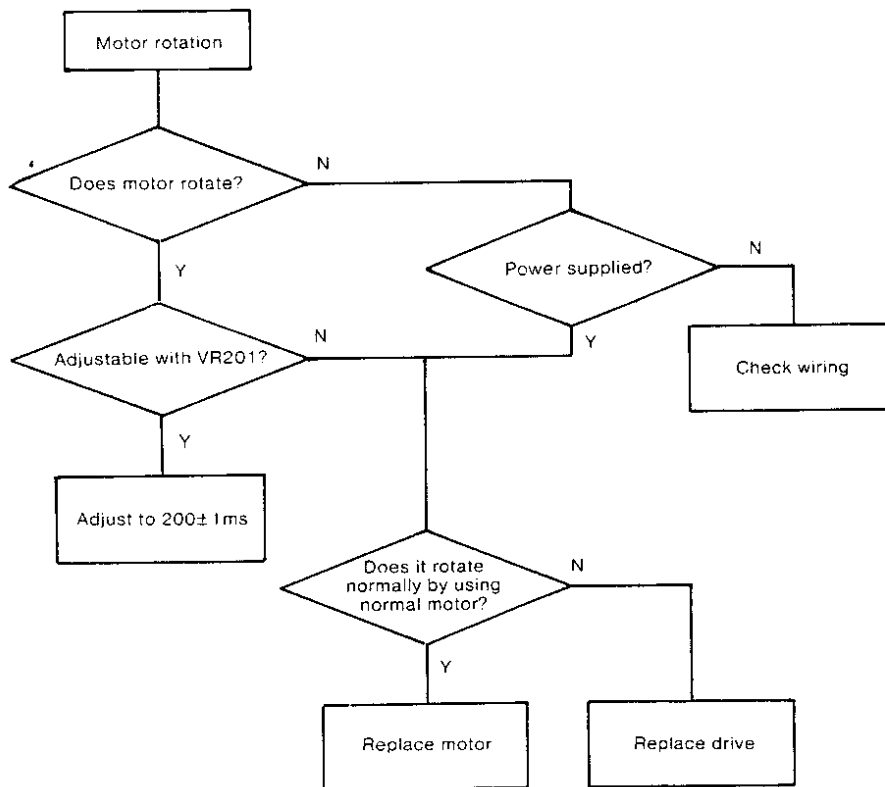

3-C

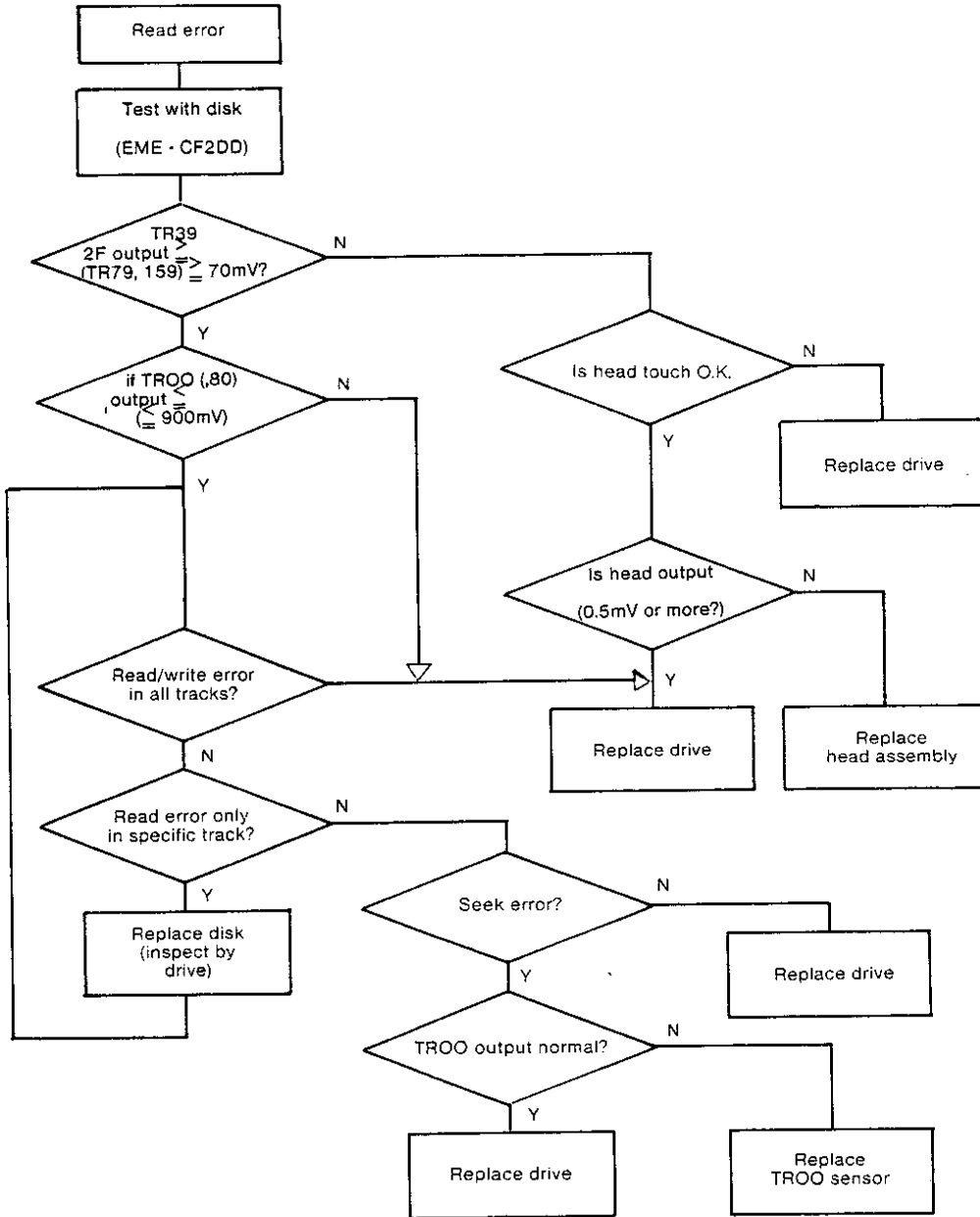

FLOW CHART (CONT)

3-D

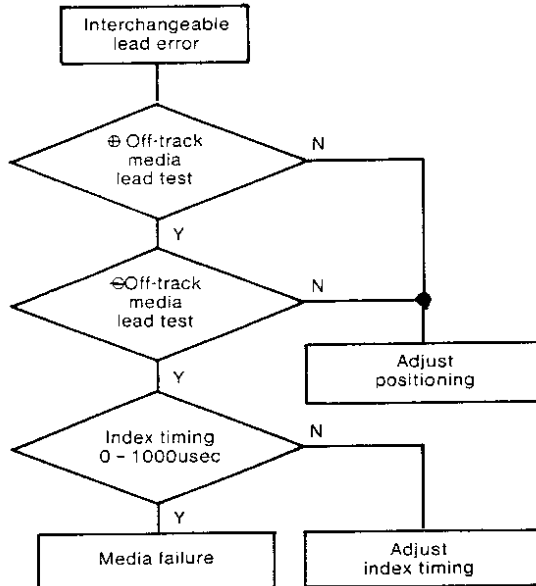
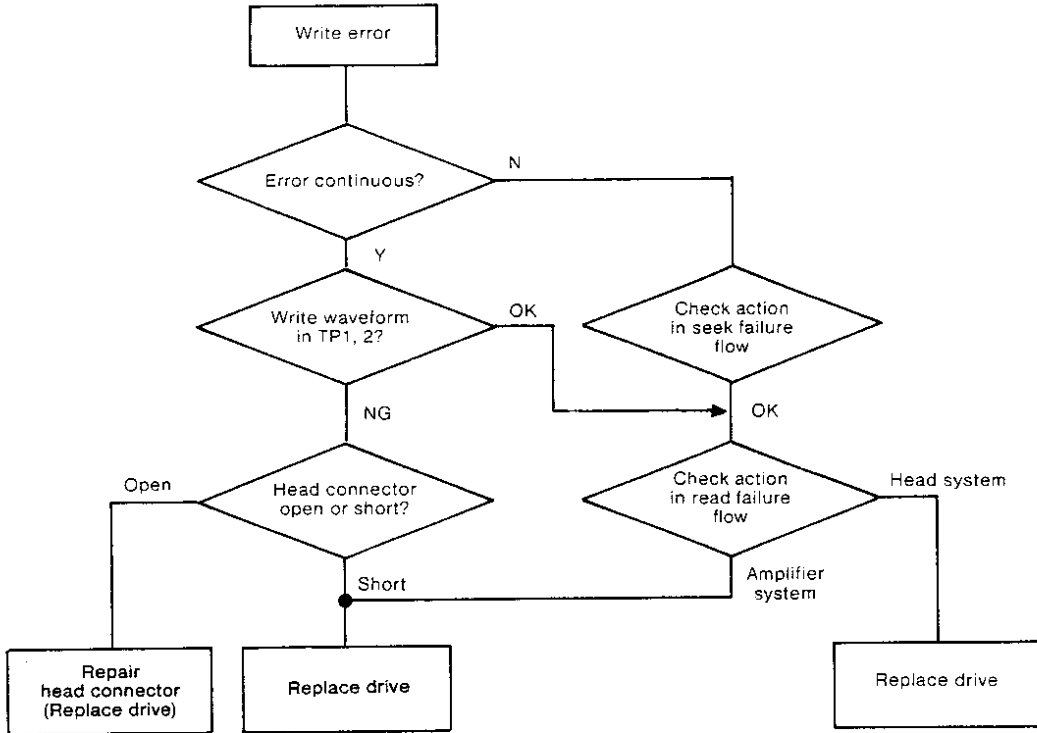

FLOW CHART (CONT) FOR FD2 ONLY

3-E

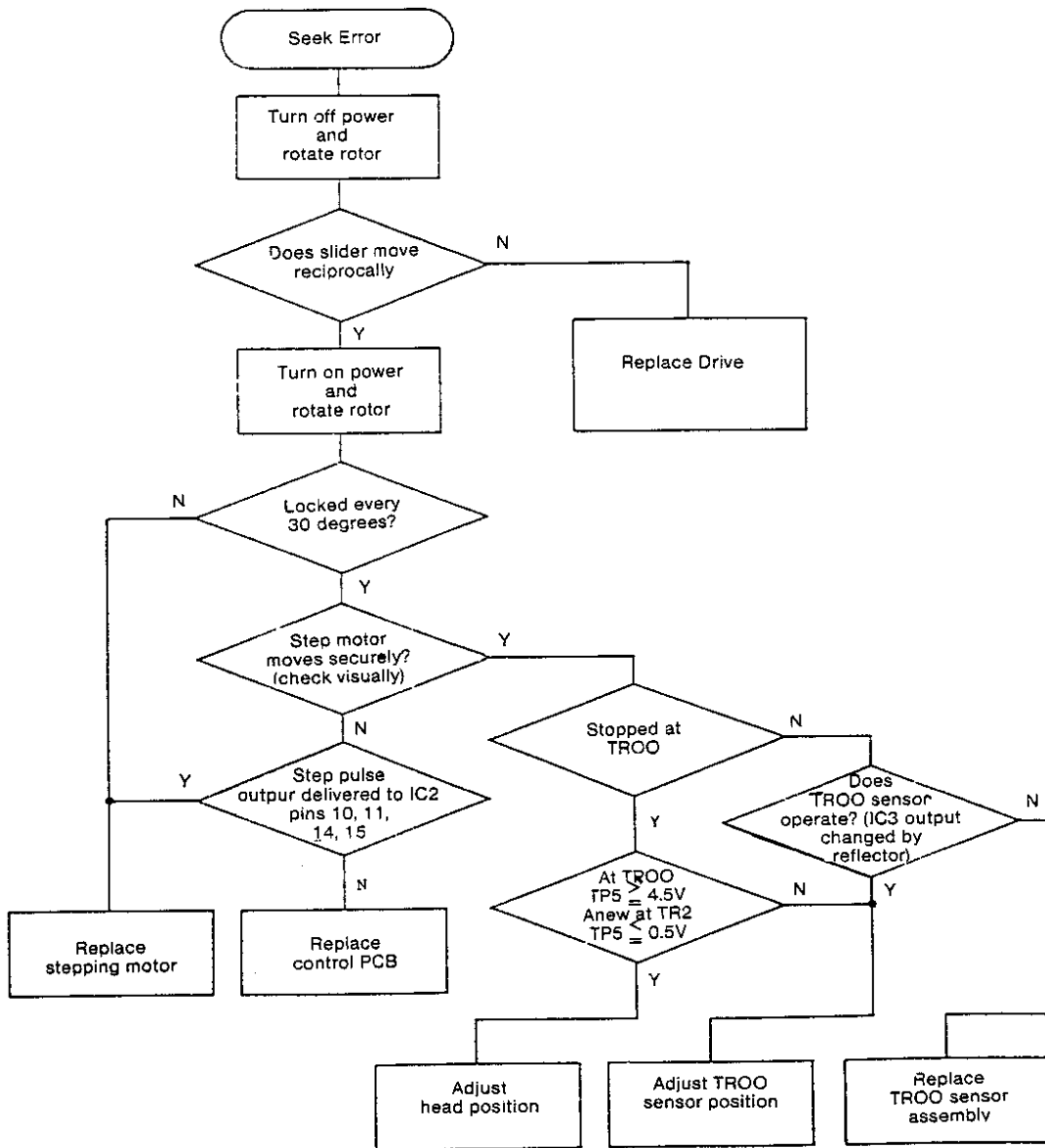

MECHANICAL REPLACEMENTS

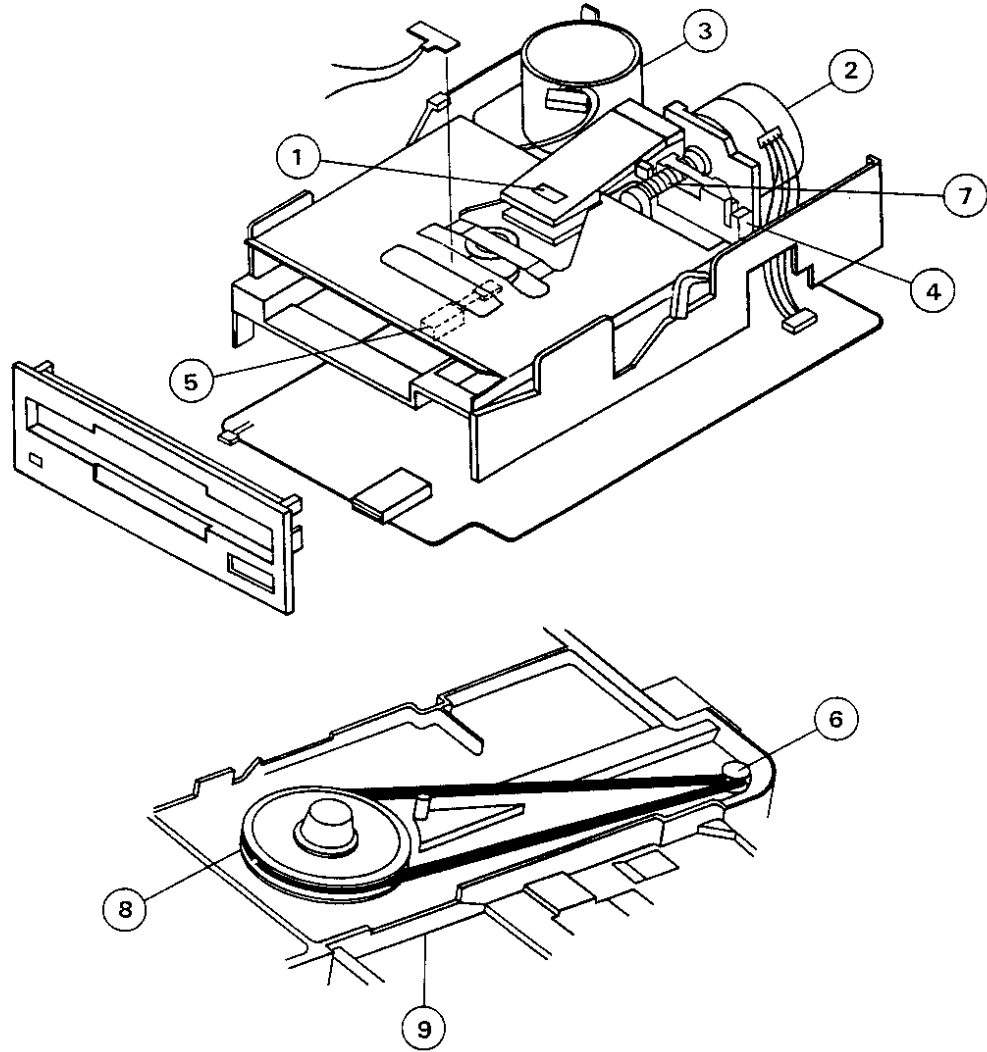

Sym	Description
1.	Head Bracket Assembly
2.	Stepper Motor
3.	Spindle Motor
4.	Track 00 Sensor
5.	Read/Write Protect Index/LED P.C.B.
6.	Pulley
7.	Stepper Motor Shaft
8.	Flywheel
9.	Loading Unit

The data contained in the following 4 pages is for information only. Service Agents must not carry out any repair or adjustment to the Drive mechanism and its associated PCB during warranty. Faulty mechanism must be returned to AMSTRAD for exchange.

Alignment Checks

Information within brackets is only for FD2

Please use this information in conjunction with the diagnostic flow chart.

Equipment required: Double Beam Scope; (EME - CF2DD) Test Disk (please refer to disk notes for usage).

The following checks can be carried out in routine servicing. If the wave patterns do not appear this confirms a fault with the mechanism. Before attempting any replacement check these waveforms thoroughly.

Content of adjustment and checking	CE DISK EME CF2 DD
1. Radial adjustment by use of Track 39, 119. Fig.1.	○
2. Adjustment of the index burst by use of Track 79, 159. Fig. 2.	○
3. Azimuth check by use of Track 79, 159. Fig. 3-4.	○

List of Test Points

Test point	Name of signal
TP 1	Read signal of filter outlet
TP 2	Read signal of filter outlet
TP 3	Signal ground
TP 5	TROO sensor output
TP 44	Index signal
TP 11	Signal ground

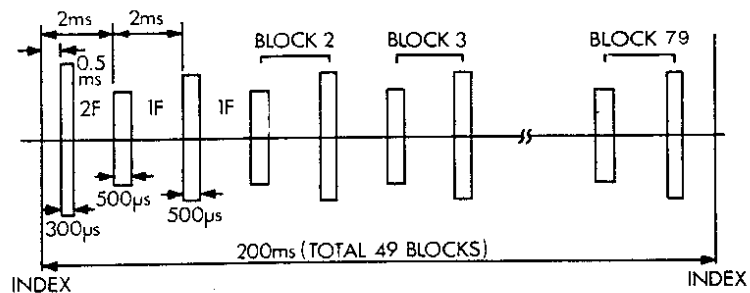

Fig. 1 Waveform of T39, 119 (Servo pattern)

ALIGNMENT CHECKS

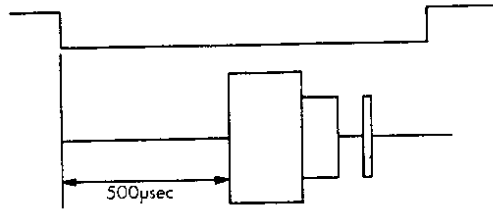

Fig. 5-1 Index burst waveform

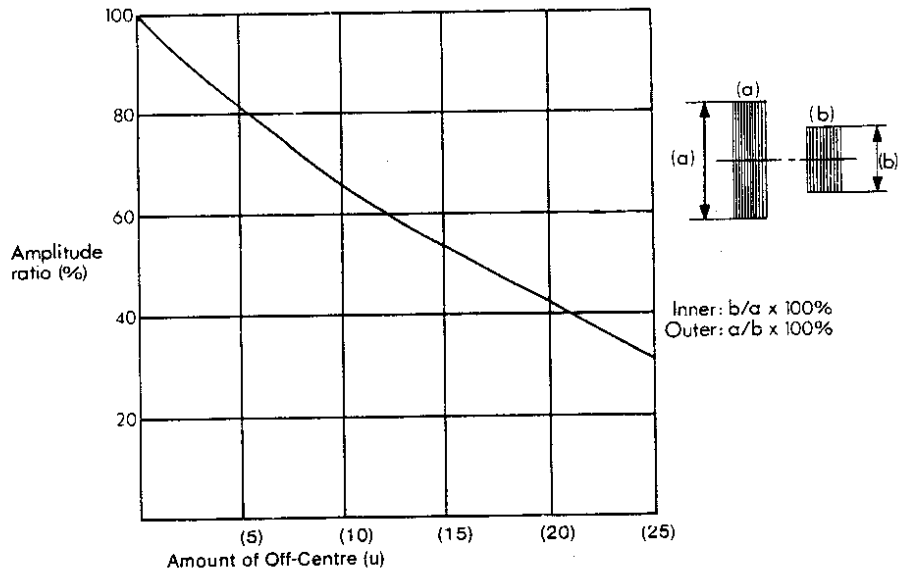

Fig. 5-2 Off-centre calibration curve
[Effective width of read head is (90u).

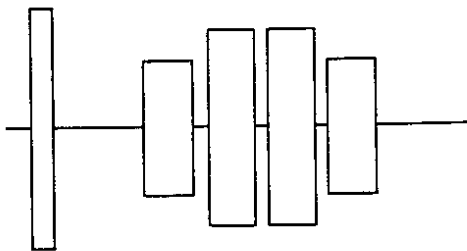

Fig. 5-3 Azimuth burst

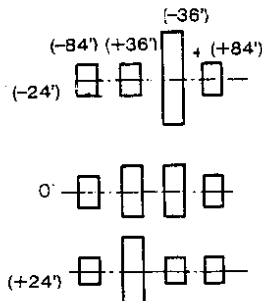

Fig. 5-4 shows azimuth burst in the cases of azimuth (-24, 0 and +24).

ALIGNMENT CHECKS (cont)

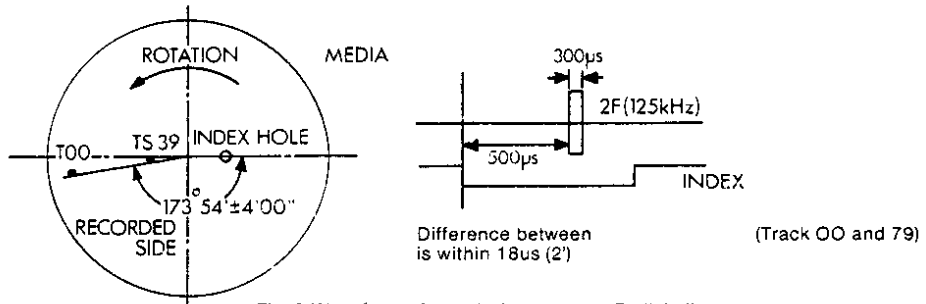

Fig. 2 Waveform of (Index pattern - Radial alignment)
(Waveform of T79, 159)

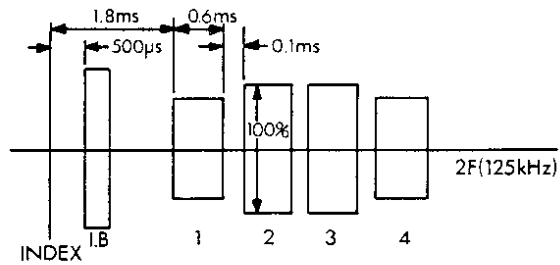

Fig. 3 Waveform of (Azimuth, alignment)
(Waveform of T79, 159)

ALIGNMENT CHECKS (cont)

1) Check Positioning

- 1) Load CE Disk.
- 2) Set up track OO, Motor off.
- 3) Scope to TP5.
- 4) Adjust OO Sensor (8 on Fig. 6) so that scope shows correct difference as Fig. 2.

2) Adjustment of Index Timing

- 1) Load the CE Disk (refer to disk info)
- 2) Step the disk to the track (Track 79).
- 3) Synchronise the oscilloscope by TP9 (INDEX). Set the time base to 0.1 msec/DIV.
- 4) Connect the probe to TP1.
Connect the ground probe to TP3 and TP11 (ground) of PCB.
Set the input to AC and set the vertical axis to 20mV/DIV.
- 5) Measure timing between sweep start and an initial data pulse. It should be 500 usec \pm 500 usec. When the timing is not within this range, proceed with the following adjustment. (Refer to Fig. 5-1).
- 6) Loosen the two screws fixed LED printed board. Adjust the position of LED printed board so that the timing is 500 usec (\pm 200 usec).
- 7) Re-check the timing.
- 8) Seek to the track OO and make sure that the timing is within 500 usec (\pm 300 usec). Tighten the screws. (Fig. 5-1).

3) Check of Head Output

This check is effective only when making write and read check as described below. If the output level is less than the prescribed output, clean the head before check.
Disk used for this check must be in good condition.

- 1) Load the CE Disk. (EME CF2DD).
- 2) Select track (Track 79).
- 3) Connect one of the probes of the oscilloscope to TP1 of the printed circuit board, another probe to TP2, and the probe to ground to TP3, TP11 (ground). Invert one channel, and set it to Add input, set input to AC, and set the vertical axis to 50mV/DIV and the horizontal axis to 20msec/DIV.
- 4) Make sure the average output level is the following value or more: (70 mV p-p) [SN 25dB or more]. If the output is less than the above-described value, replace the head.

4) Adjustment of Positioning

- 1) Load the CE disk (EME CF2DD).
- 2) Select track (Track 39).
- 3) Monitor the output in the same way as the head output inspection.
Calculate the off-track amount in reference to the calibration graph, showing the interrelation between the burst amplitude ratio and off-track amount. (Refer to Fig. 5-2).
- 4) The average of amplitude ratio should be below (19 μ m).
If it is not within this range, make the following adjustment.
 - i) Loosen the bolt of the rotation stopper which fixes the screw shaft (Fig. 6-3). Rotate the screw shaft and adjust it in such a way that the amplitude ratio may become below (5 μ m). Tentatively set the bolt at that position.
 - ii) Make the track step to the inner and outer circles and bring it to the original position. Make sure that the adjustment is all right. Then, tighten the bolt.

5) Confirmation of Head Azimuth

- 1) Load the CE Disk (EME CF2DD).
- 2) Select track (Track 79).
- 3) Synchronise the probe of the oscilloscope by TP9 of PCB and connect another probe to TP1, and the probe ground to TP3, TP11 (ground). Set the input to AC, the vertical axis to 10mV/DIV, and the horizontal axis to 0.5msec/DIV. Make sure that the two outside burst waveforms are smaller than two inside burst waveforms as shown in Fig. 5-3.
Note: Signal preceding the azimuth burst is the index burst.
If the azimuth is still incorrect replace the head assembly.

FD4 SCHEMATIC DIAGRAM

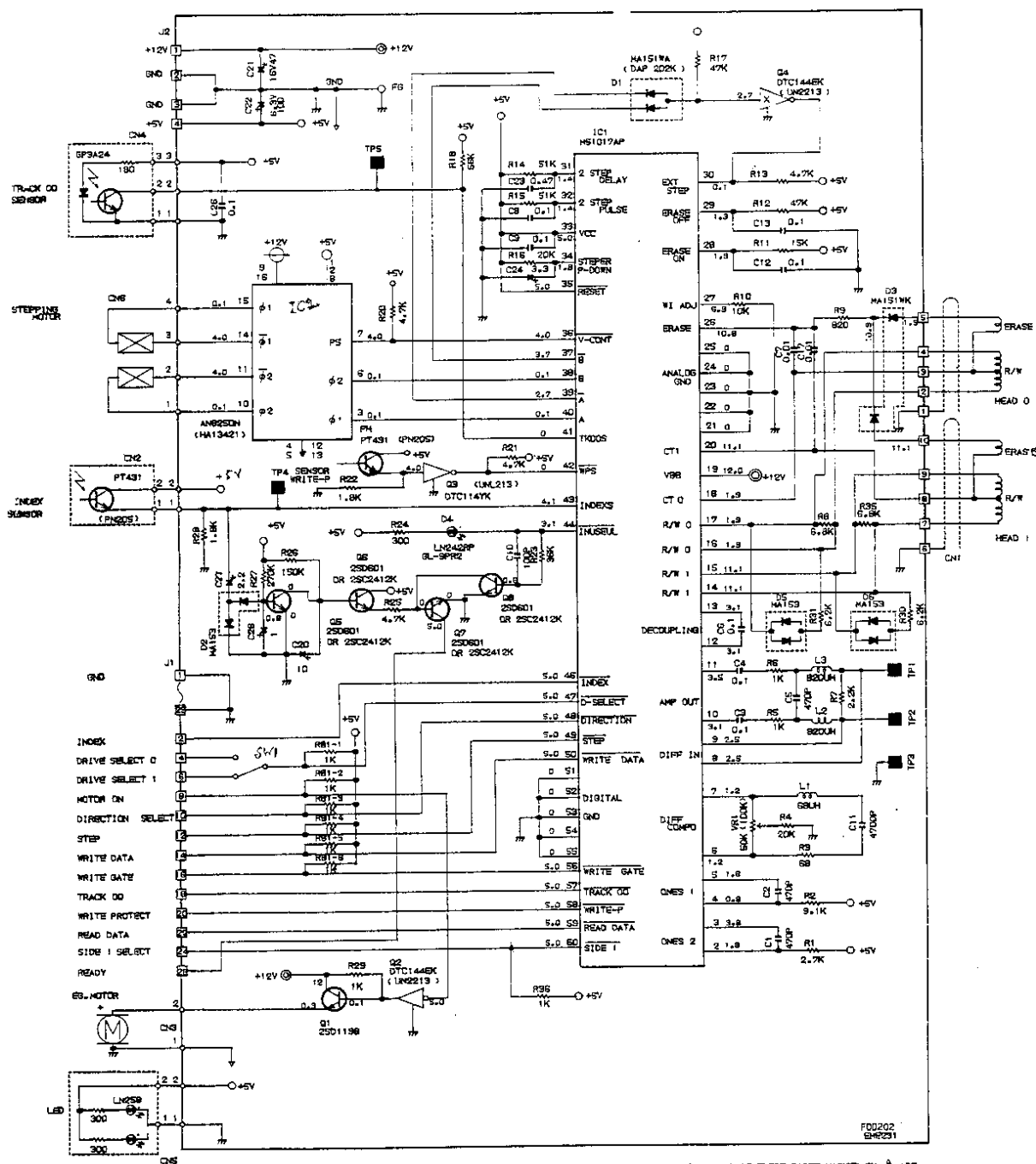

CAUTION: SINCE THESE PARTS MARKED BY Δ ARE CRITICAL FOR SAFETY, USE ONES DESCRIBED ON PARTS LIST ONLY.